













Economical, Subminiature Basic Switch Offers Long Life (30 x 10⁶ Operations)

- Incorporating simple and stable two split springs which ensures a long service life (30,000,000 operations).
- A variety of models with low operating force to high operating force are available.
- Solder, quick-connect (#110) and PCB terminals are available.
- Wide switching capacity range from micro-voltage/current loads (1 mA at 5VDC) to high capacity loads (10.1 A at 250 VAC)



Ordering Information

Note: A number of other lever options are available. See Note 2 under dimensions or contact Omron.

Rating	Actuator	OF max.	Soldering terminal	Quick-connect terminal (#110)	PCB terminal
0.1 A (bifurcated crossbar contacts for microvoltage/current load)	Pin plunger 	25 g	SS-01-E	SS-01-ET	SS-01-ED
		50 g	SS-01-F	SS-01-FT	SS-01-FD
		150 g	SS-01	SS-01-T	SS-01D
	Standard lever 	8 g	SS-01GL-E	SS-01GL-ET	SS-01GL-ED
		16 g	SS-01GL-F	SS-01GL-FT	SS-01GL-FD
		50 g	SS-01GL	SS-01GLT	SS-01GLD
	Simulated roller lever 	8 g	SS-01GL13-E	SS-01GL13-ET	SS-01GL13-ED
		16 g	SS-01GL13-F	SS-01GL13-FT	SS-01GK13-FD
		50 g	SS-01GL13	SS-01GL13T	SS-01GL13D
	Standard roller lever 	8 g	SS-01GL2-E	SS-01GL2-ET	SS-01GL2-ED
		16 g	SS-01GL2-F	SS-01GL2-FT	SS-01GL2-FD
		50 g	SS-01GL2	SS-01GL2T	SS-01GL2D
5 A (standard rivet contact)	Pin plunger 	50 g	SS-5-F (see note)	SS-5-FT	SS-5-FD (see note)
		150 g	SS-5 (see note)	SS-5T	SS-5D (see note)
	Standard lever 	16 g	SS-5GL-F (see note)	SS-5GL-FT	SS-5GL-FD (see note)
		50 g	SS-5GL (see note)	SS-5GLT	SS-5GLD (see note)
	Simulated roller lever 	16 g	SS-5GL13-F (see note)	SS-5GL13-FT	SS-5GL13-FD (see note)
		50 g	SS-5GL13 (see note)	SS-5GL13T	SS-5GL13D (see note)
	Standard roller lever 	16 g	SS-5GL2-F (see note)	SS-5GL2-FT	SS-5GL2-FD (see note)
		50 g	SS-5GL2 (see note)	SS-5GL2T	SS-5GL2D (see note)
10.1 A (standard rivet contact)	Pin plunger 	150 g	SS-10 (see note)	SS-10T	SS-10D (see note)
	Standard lever 	50 g	SS-10GL (see note)	SS-10GLT	SS-10GLD (see note)
	Simulated roller lever 	50 g	SS-10GL13 (see note)	SS-10GL13T	SS-10GL13D (see note)
	Standard roller lever 	50 g	SS-10GL2 (see note)	SS-10GL2T	SS-10GL2D (see note)

Note: EN61058-1 (IEC1058-1) approved by TÜV Rheinland.

Model Number Legend

SS-□□□□
1 2 3 4

1. Ratings

01: 0.1 A
5: 5 A
10: 10 A

2. Actuator

None: Pin plunger
GL: Hinge lever
GL13: Simulated hinge lever
GL2: Hinge roller lever

3. OF Max. (at Pin Plunger)

None: 150 gf
-F: 50 gf
-E: 25 gf

4. Terminals

None: Solder
T: Quick-connect (#110)
D: PCB

Specifications

Ratings

Type	Rated voltage	SS-10, SS-5								SS-01	
		Non-inductive load				Inductive load				Non-inductive load	
		Resistive load		Lamp load		Inductive load		Motor load		Resistive load	
		NC	NO	NC	NO	NC	NO	NC	NO	NC	NO
General-purpose	125 VAC	5 (10.1) A		1.5 A	0.7 A	3 A		2.5 A	1.3 A	0.1 A	
	250 VAC	3 (10.1) A		1 A	0.5 A	2 A		1.5 A	0.8 A	---	
	8 VDC	5 (10.1) A		2 A		5 A	4 A	3 A		---	
	14 VDC	5 (10.1) A		2 A		4 A	4 A	3 A		---	
	30 VDC	4 A		2 A		3 A	3 A	3 A		0.1 A	
	125 VDC	0.4 A		0.05 A		0.4 A	0.4 A	0.05 A		---	
	250 VDC	0.2 A		0.03 A		0.2 A	0.2 A	0.03 A		---	

- Note:**
1. Inductive load has a power factor of 0.4 min. (AC) and a time constant of 7 ms max. (DC).
 2. Lamp load has an inrush current of 10 times the steady-state current.
 3. Motor load has an inrush current of 6 times the steady-state current.
 4. Data in parentheses apply to the SS-10 series only.
 5. If the switch is used in a DC circuit and is subjected to a surge, connect a surge suppressor across the switch.

Contact Form

The normally open (SPST-NO) and normally closed (SPST-NC) types are not listed under *Ordering Information*. Consult OMRON directly.

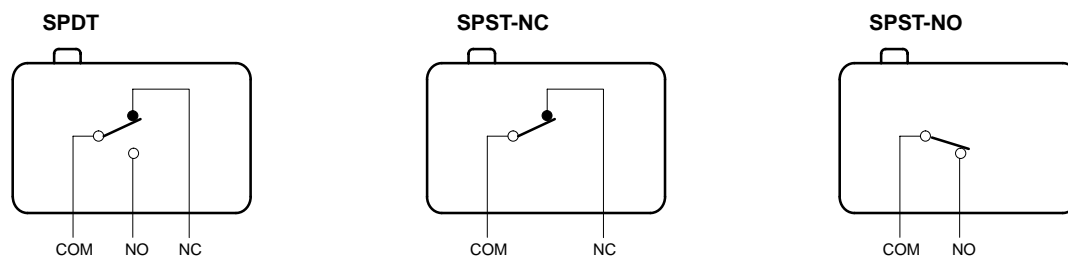

Approved Standards

UL (File No. E32667)/CSA (File No. LR21642)

SS-10 series: 10.1 A at 250 VAC
SS-5 series: 5 A at 125 VAC, 3 A at 250 VAC
SS-01 series: 0.1 A at 125 VAC, 0.1 A at 30 VDC

SEMKO (File No. 8614026)/VDE (File No. 221)

SS-5 series: 5 A at 250 VAC

SEMKO (File No. 8916091)/VDE (File No. 221)

SS-10 series: 10 A at 250 VAC

SEV (File No. 93, 5, 51936, 01)

SS-5 series: 5 A at 250 VAC

EN61058-1 (IEC1058-1) (TÜV Rheinland, File No. T9451450)

SS-5: 5 A at 250 VAC, 5(1) A at 250 VAC

SS-10: 10 A at 250 VAC

■ Characteristics

Operating speed	0.1 mm to 1 m/s (at pin plunger)
Operating frequency	Mechanical: 400 operations/min Electrical: 60 operations/min
Insulation resistance	100 MΩ min. (at 500 VDC)
Contact resistance (initial value)	OF 150 gf: SS-01 series: 50 mΩ max. SS-5, SS-10 series: 30 mΩ max. OF 50 gf: SS-01 series: 100 mΩ max. SS-5 series: 50 mΩ max. OF 25 gf: SS-01 series: 150 mΩ max.
Inrush current	NC: 20 A max. for SS-10 and SS-5, 1 A max. for SS-01 NO: 15 A max. for SS-10, 10 A max. for SS-5, 1 A max. for SS-01
Dielectric strength	1,000 VAC (600 VAC for crossbar contact model), 50/60 Hz for 1 min between the same polarities 1,500 VAC, 50/60 Hz for 1 min between current-carrying metal part and ground, and between each terminal and non-current-carrying metal part
Vibration resistance	Malfunction: 10 to 55 Hz, 1.5-mm double amplitude
Shock resistance	Mechanical: OF 150 gf: 1,000 m/s ² (approx. 100G min.) OF 25/50 gf: 500 m/s ² (approx. 50G min.) Malfunction: OF 150 gf: 300 m/s ² (approx. 30G min.) OF 25/50 gf: 200 m/s ² min. (approx. 20G min.) Note: Lever-type model: Operating limit position (with a contact separation time of 1 ms max.)
Life expectancy	Mechanical: 30,000,000 operations min. (OT: rated value) 10,000,000 operations min. for SS-10 series Electrical: 200,000 operations min. (OT: full) 50,000 operations min. for SS-10 series
Ambient temperature	Operating: -25°C to 85°C (with no icing)
Ambient humidity	Operating: 85% max.
Contact	Type: Rivet for SS-10 and SS-5, crossbar for SS-01 Material: Silver alloy for SS-10, silver for SS-5, PGS alloy for SS-01
Weight	Approx. 1.6 g (pin plunger)

Characteristics Approved by TÜV Rheinland for EN61058-1

Enclosure rating	IP00
Degree of protection against electrical shock	Class 1
Ambient temperature	0°C to 85°C (with no icing)
Operating cycles	50,000
Proof Tracking Index (PTI)	175 V
Switch category	D

■ Operating Characteristics

Model	SS-01-E	SS-01-F, SS-5-F	SS-01, SS-5	SS-10
OF max.	0.25 N (25 gf)	0.49 N (50 gf)	1.47 N (150 gf)	1.47 N (150 gf)
RF min.	0.02 N (2 gf)	0.04 N (4 gf)	0.25 N (25 gf)	0.25 N (25 gf)
PT max.	0.5 mm	0.5 mm	0.5 mm	0.6 mm
OT min.	0.5 mm	0.5 mm	0.5 mm	0.4 mm
MD max.	0.1 mm	0.1 mm	0.1 mm	0.12 mm
OP	8.4±0.5 mm			

Model	SS-01GL-E	SS-01GL-F, SS-5GL-F	SS-01GL, SS-5GL	SS-10GL
OF max.	0.08 N (8 gf)	0.16 N (16 gf)	0.49 N (50 gf)	0.49 N (50 gf)
RF min.	(0.01 N (1 gf))	0.02 N (2 gf)	0.06 N (6 gf)	0.06 N (6 gf)
OT min.	1.2 mm	1.2 mm	1.2 mm	1.0 mm
MD max.	0.8 mm	0.8 mm	0.8 mm	1.0 mm
FP max.	13.6 mm			
OP	8.8±0.8 mm			

Note: Values in brackets are possible when the switch is mounted so that the weight of the lever will not be imposed on the plunger.

Model	SS-01GL13-E	SS-01GL13-F, SS-5GL13-F	SS-01GL13, SS-5GL13	SS-10GL13
OF max.	0.08 N (8 gf)	0.16 N (16 gf)	0.49 N (50 gf)	0.49 N (50 gf)
RF min.	(0.01 N (1 gf))	0.02 N (2 gf)	0.06 N (6 gf)	0.06 N (6 gf)
OT min.	1.2 mm	1.2 mm	1.2 mm	1.0 mm
MD max.	0.8 mm	0.8 mm	0.8 mm	1.0 mm
FP max.	15.5 mm			
OP	10.7±0.8 mm			

Model	SS-01GL2-E	SS-01GL2-F, SS-5GL2-F	SS-01GL2, SS-5GL2	SS-10GL2
OF max.	0.08 N (8 gf)	0.16 N (16 gf)	0.49 N (50 gf)	0.49 N (50 gf)
RF min.	(0.01 N (1 gf))	0.02 N (2 gf)	0.06 N (6 gf)	0.06 N (6 gf)
OT min.	1.2 mm	1.2 mm	1.2 mm	1.0 mm
MD max.	0.8 mm	0.8 mm	0.8 mm	1.0 mm
FP max.	19.3 mm			
OP	14.5±0.8 mm			

Note: Values in brackets are possible when the switch is mounted so that the weight of the lever will not be imposed on the plunger.

Engineering Data

Mechanical Life Expectancy

SS-5, SS-01 Series

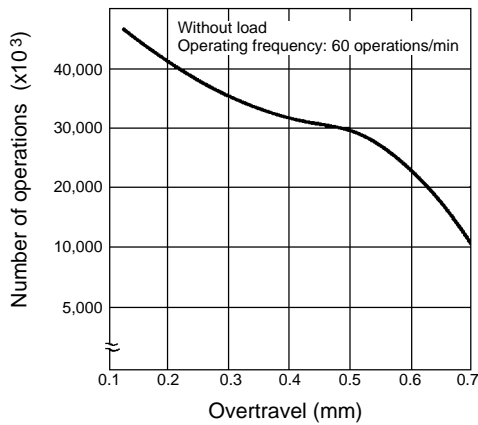

Electrical Life Expectancy

SS-5 Series

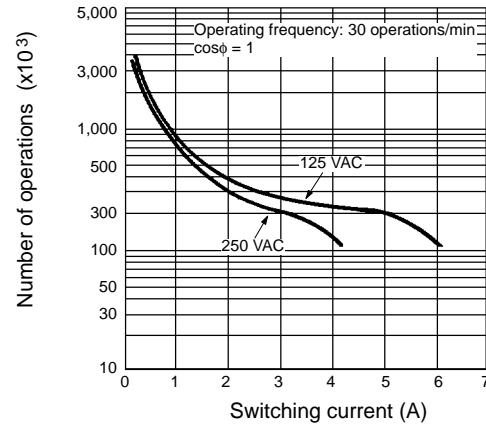

Dimensions

- Note:**
1. All units are in millimetres unless otherwise indicated.
 2. Unless otherwise specified, a tolerance of ± 0.4 mm applies to all dimensions.
 3. The following illustration and drawing are for solder terminal models. Refer to page NO TAG for details on models with quick-connect terminals (#110) or PCB terminals.

Pin Plunger

SS-01(-E, -F)
SS-5(-F)
SS-10

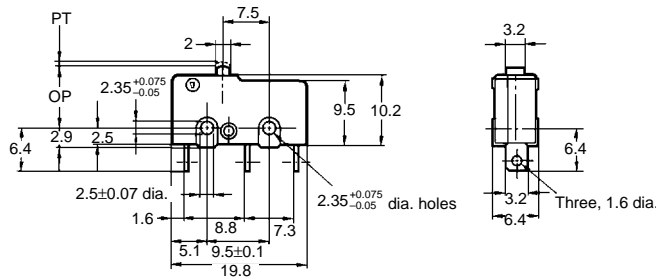
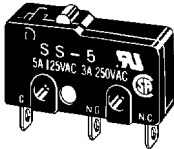

Standard Lever

SS-01GL(-E, -F)
SS-5GL(-F)
SS-10GL

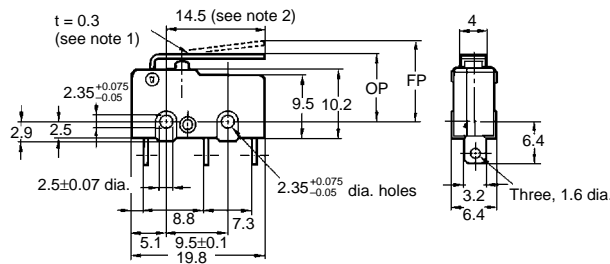
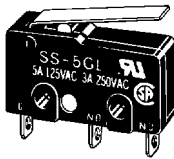

- Note:**
1. Stainless steel lever
 2. Besides the SS-□GL-series models with a hinge lever length of 14.5, the SS-□GL11-series models with a hinge lever length of 18.5, the SS-□GL111-series models with a hinge lever length of 22.6, and the SS-□GL1111-series models with a hinge lever length of 37.8 are available. Contact your OMRON representative for these models

Simulated Roller Lever

SS-01GL13(-E, -F)
SS-5GL13(-F)
SS-10GL13

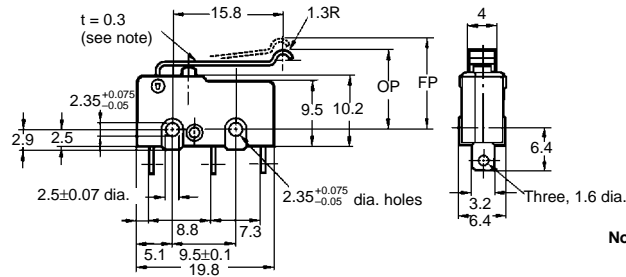
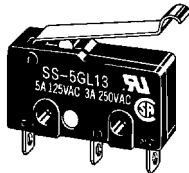

Note: Stainless steel spring lever

Standard Roller Lever

SS-01GL2(-E, -F)
SS-5GL2(-F)
SS-10GL2

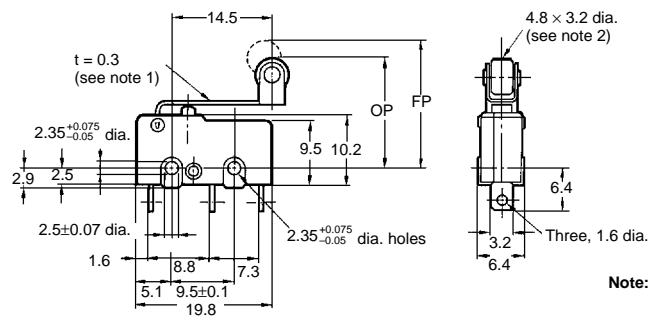
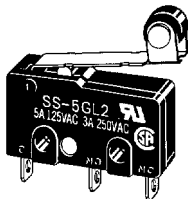

- Note:**
1. Stainless steel spring lever
 2. Polyacetal resin roller

■ Terminals

Solder Terminal

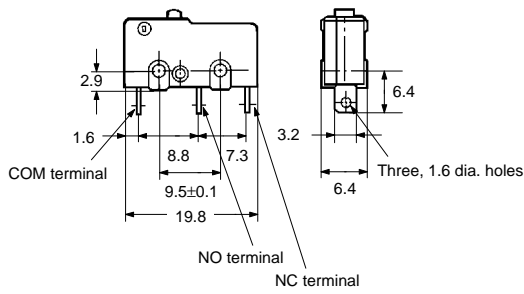

Quick-connect Terminal (#110)

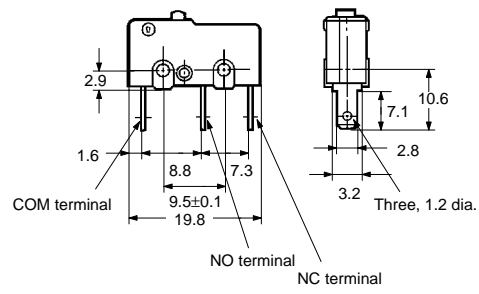

PCB Terminal

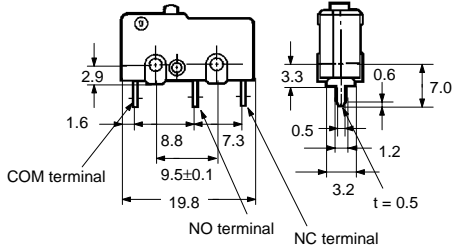

PCB Mounting Dimensions (Reference)

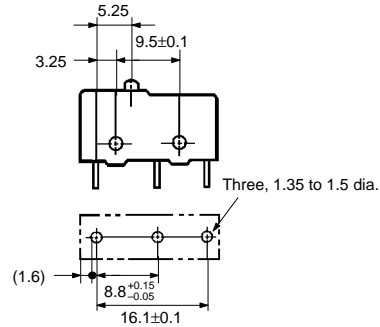

Precautions

Mounting

Use two M2.3 mounting screws with spring washers to mount the switch. Tighten the screws to a torque of 0.23 to 0.27 N • m (2.3 to 2.7 kgf • cm).

Mounting Holes

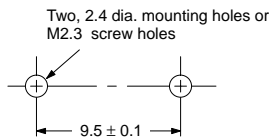

Actuating

For the secure operation, 60% to 90% of rated overtravel should be maintained.

Spacing

Switch does not have a ground terminal. The minimum thickness of insulation according to IEC1058-1 is 1.1 mm, and the minimum clearance between live terminals and mounting plate is 1.6 mm. If the proper insulation for the terminator cannot be obtained, add insulation such as a separator or insulation cover on the switch.

Soldering

When soldering switch terminals, apply a soldering iron rated at 60 W max. and finish soldering quickly within 5 seconds. During soldering and 1 minute after soldering, do not apply external force to the terminals. Solder terminals are provided with a hole for the mechanical mounting of a conductor. Conductors for the soldering terminal should be flexible and its cross-section should be 0.5 to 0.75 mm² for the SS-5 series and 0.75 mm² for the SS-10 series.

Others

If a surge current or inrush current is involved in a DC circuit, it is recommended to use a cancellation circuit.